



TEXAS A&M
FOREST SERVICE

WILDFIRE RECOVERY

SOIL EROSION CONTROL PRACTICE GUIDE



September 2012

About this guide:

This practice guide is intended to be a resource for landowners and resource professionals working directly with landowners impacted by wildfire. It presents general guidance, tools, and references for selecting and implementing common soil erosion control treatments that have been proven effective for post-fire rehabilitation. The practices included in this guide were selected because of their non-technical and intuitive nature. Information is included on the primary use and purpose of each treatment, suitable locations for treatment implementation, available information on treatment effectiveness, and references for additional reading which include more technical implementation specifications and recommendations.

The need for, and implementation of, any given practice is a site specific determination and will require consideration of local conditions, the potential for soil erosion and sedimentation, climate, available resources and cost, geography, vegetation response, land use, and weather. This practice guide should be used as general guidance for treatment selection and implementation. Assistance from a trained professional may still be necessary as incorrectly implementing a practice could result in detrimental impacts to the environment and/or unnecessary economic loss.

CONTACT:

Texas A&M Forest Service

Water Resources
P.O. Box 310
Lufkin, TX 75901-0310

(936) 639-8180 (office)

(936) 639-8185 (fax)

<http://texasforests.tamu.edu/water>

Table of Contents:

Practice Selection Guide

Contour Felling	5
Erosion Control Mats.....	6
Fiber Rolls / Straw Wattles	7
Hydromulching	8
Mulching	
Slash Spreading.....	9
Straw Mulch Spreading	10
Seeding.....	11
Silt Fence.....	12

PRACTICE SELECTION GUIDE

Practice	Burn Severity	Treatment Area Size	Slopes	Other Conditions	Treatment Effectiveness*										Relative Cost
					Reduce Erosion	Increase Cover	Improve Moisture Retention	Reduce Slope Length	Slow Runoff Velocity	Trap Sediment	Increase Infiltration	Provide a Seedbed	Provide Surface Roughness	Overall Rating	
Contour Felling	Moderately to Heavily	Moderate to Large	Moderate to Steep	Must have a large number of straight trees 8-12 inches in diameter and 15-20 feet long	2	N/A	N/A	2	1	2	2	N/A	N/A	Good-Excellent	\$\$
Erosion Control Mats	Heavily	Small	Moderate to Steep	Short slopes, limited ground material, rocks, or debris	1	1	1	N/A	2	3	1	1	2	Excellent	\$\$\$\$
Fiber Rolls / Straw Wattles	Moderately to Heavily	Small to Moderate	Moderate to Steep	Should not be placed across drainages, swales, or channels with more than 2 acres of contributing area	2	N/A	N/A	2	1	2	2	N/A	N/A	Fair-Excellent	\$\$
Hydromulching	Heavily	Small to Moderate	Low to Moderate	Slopes lacking effective soil cover with no needle-cast or regrowth potential within the first year	2	2	2	N/A	2	N/A	2	2	2	Excellent	\$\$\$
Mulch Spreading: Slash	Moderately	Small to Moderate	Low to Moderate	Areas burned but with available slash on site	2	2	1	N/A	2	3	2	N/A	2	Fair-Good	\$\$
Straw (weed-free)	Moderately to Heavily	Small to Moderate	Low to Moderate	Straw can blow away in high wind areas	1	1	1	N/A	2	N/A	1	2	1	Excellent	\$\$
Seeding	Moderately to Heavily	Moderate to Large	Low to Moderate	May require some sort of cover like weed-free straw or light mulch	2	2	N/A	N/A	2	N/A	2	N/A	2	Good	\$
Silt Fence	Moderately to Heavily	Small	Low to Moderate	Contributing drainage area should not exceed 10,000 ft ²	2	N/A	N/A	1	1	1	N/A	N/A	N/A	Good-Excellent	\$

* 1 = Fully meets objective, 2 = Partially meets objective, 3 = Rarely or seldom meets objective

Treatment: CONTOUR FELLING

Description: Contour felling involves felling, positioning, and anchoring dead trees on the contour of a burned slope where erosion rates are expected to be high (i.e., moderate to steep slopes and/or highly erosive soils, particularly those adjacent to surface water features, which have been partially or completely denuded of vegetation). The logs are positioned along the contour of the slope, perpendicular to the flow of water, and in an alternating pattern.

Purpose: Contour felling controls erosion by shortening the slope length to slow overland flow velocity. The less distance that water can travel the less velocity it can gain, and therefore, the less sediment it can carry. Log barriers also function to trap sediment and retain it on site (similar to silt fences).

Methods and Guidelines:

- Trees must be placed exactly along the contour. Studies have shown that misplacing logs more than 2 to 5 degrees off contour causes the trap efficiency to decrease by at least 20 percent.
- Tree limbs should be removed to the extent necessary for the log to lie flat on the ground, encouraging the collection of water and trapping debris moving down the slope.
- Logs must be securely anchored on the downhill side so they don't roll down the slope.
- A trench 8 to 12 inches deep should be dug on the uphill side of each log to catch debris. This soil should be tamped into any gaps between the log and the ground to prevent water from running under the barrier.
- For this practice to be effective, enough trees must be felled along the contour line to create a semi-continuous barrier to the movement of water down the slope. This requires approximately 400 to 600 feet of straight logs per acre (or about 30 logs 15 to 20 feet long and 6 to 12 inches in diameter). If the log material is not available, consider using fiber rolls or straw wattles instead.

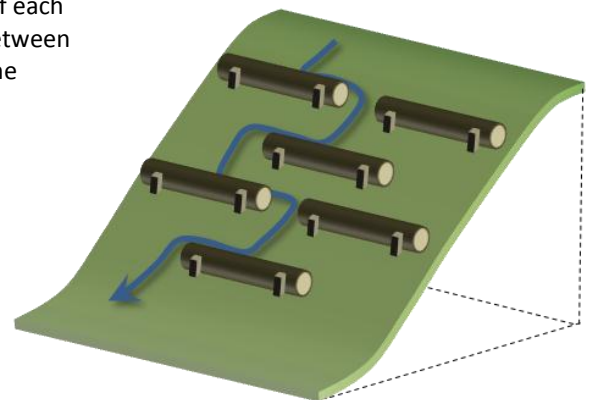
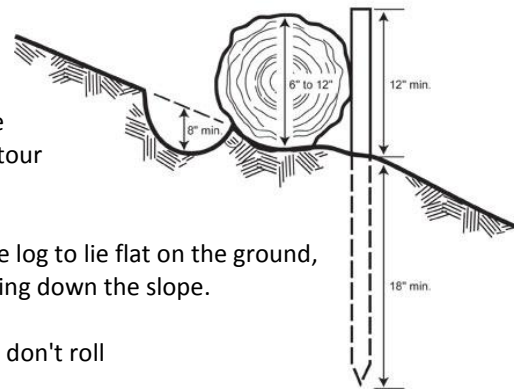

- Logs or slash from the felling should not be placed in drainages or swales.
- Log barriers should be viewed as a short-term fix, as some structures fill with sediment after the first substantial storm event following a burn, while others may take one to two years to fill.

Additional Information:

USDA Forest Service Burned Area Emergency Response Treatment Catalog: (pages 41-48)
http://www.fs.fed.us/eng/pubs/pdf/BAERCAT/lo_res/06251801L.pdf

NRCS Contour Log Felling Fact Sheet:
<http://www.mt.nrcs.usda.gov/technical/eng/ewp/logfelling.html>

Treatment: EROSION CONTROL MATS

Description: Erosion control mats are used to temporarily stabilize and protect burned areas highly vulnerable to erosion until vegetation can establish. They are either synthetic or organic and temporary (last for several months) or permanent (last for several years). Organic erosion control mats are typically biodegradable and made from a variety of materials such as straw, excelsior, coconut fiber, or a combination thereof. They are typically secured to the ground with wooden stakes or wire staples. Their use is especially appropriate for small areas and critical slopes adjacent to sensitive areas, such as streams and wetlands.

Purpose: Erosion control mats prevent erosion caused by raindrop impact and absorb overland flow by creating immediate cover and holding the soil in place. They also reduce soil temperature and provide moisture conservation, which fosters site revegetation.

Methods and Guidelines:

- For erosion control mats to be effective they must make good contact uniformly with the ground. Rocks and other obstructions (e.g., branches, stumps, etc.) which rise above the level of the soil must be removed.
- Individual rolls of erosion control mats should be applied up and down the slope - never along the contour. The upper end of each mat at the top of the disturbed area should be buried in a trench at least 8 to 12 inches deep. Rolls should be laid out so that the edges overlap each other by at least 6 inches across the slope, and by at least 3 feet when overlapping down the slope (placed end over end, shingle style). Be sure to account for this overlap when estimating how much matting you will need.
- Staple blankets sufficiently to anchor in place and maintain contact with the soil.
- Inspect blankets weekly and after each rain event (of 0.5 inches or more) to locate and repair any damage.

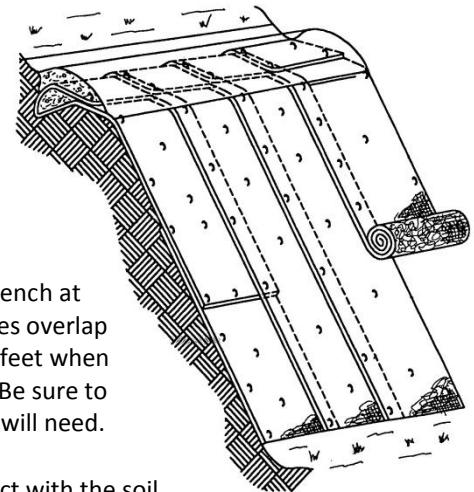

Additional Information:

USDA Forest Service Burned Area Emergency Response Treatment Catalog: (pages 35-39)
http://www.fs.fed.us/eng/pubs/pdf/BAERCAT/lo_res/06251801L.pdf

LCRA Details for Erosion and Sediment Control after a Fire Event: (page 6)
http://www.lcra.org/library/media/public/docs/water/quality/water_WQ_ESCFireDetail.pdf

NRCS Erosion Control Netting Fact Sheet:
<http://www.wy.nrcs.usda.gov/technical/ewpfactsheets/ecnet.html>

EPA Geotextiles Fact Sheet:
<http://cfpub.epa.gov/npdes/stormwater/menuofbmps/index.cfm?action=browse&Rbutton=detail&bmp=45&minmeasure=4>

County of Orange, California - Protecting Your Property from Soil Erosion: (section EC-7, pages 1-11)
<http://www.ocpublicworks.com/docs/SoilErosion.pdf>

Treatment: FIBER ROLLS / STRAW WATTLES

Description: Fiber rolls, commonly called wattles, consist of straw, coconut fibers, mulch or other similar materials bound into a tight tubular roll of natural or degradable synthetic containment mesh. Fiber rolls are used along burned slopes vulnerable to erosion (i.e., moderate to steep slopes and/or highly erosive soils, particularly those adjacent to surface water features, which have been partially or completely denuded of vegetation). They are anchored onto the slope along the contour, perpendicular to the flow of water.

Purpose: Fiber rolls control erosion by shortening the slope length to slow overland flow velocity. The less distance that water can travel the less velocity it can gain, and therefore, the less sediment it can carry. Because of their permeability, fiber rolls can also filter sediments from intercepted overland flows. They can be used in areas where contour felling is not feasible due to log material limitations.

Methods and Guidelines:

- Use only certified weed-free straw as problems can arise with straw containing exotic or invasive weeds. Noxious weeds displace native plants and decrease wildlife habitat, plant productivity, and diversity.
- Since water flows through straw logs instead of around them (as with contour felled trees), staggering the straw logs is not necessary. Vertical spacing of fiber rolls is highly variable. Consult manufacturer guidelines, as well as burn severity maps, and erosion-hazard ratings for slopes.
- Complete ground contact and firm anchoring are essential for fiber rolls to function effectively. The last 2 to 3 feet of the straw wattle should be turned upslope to prevent water and sediment from going around the structure and to increase storage capacity.
- Straw wattles should not be placed across drainages, swales, or channels with more than 2 acres of contributing area because they are not sturdy enough to resist the forces of concentrated flows.

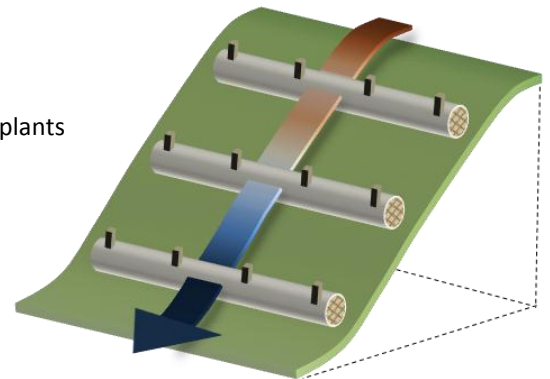

Additional Information:

USDA Forest Service Burned Area Emergency Response Treatment Catalog: (pages 49-54)
http://www.fs.fed.us/eng/pubs/pdf/BAERCAT/lo_res/06251801L.pdf

LCRA Details for Erosion and Sediment Control after a Fire Event: (page 5)
http://www.lcra.org/library/media/public/docs/water/quality/water_WQ_ESCFireDetail.pdf

NRCS Straw Wattle Fact Sheet:
<http://www.wy.nrcs.usda.gov/technical/ewpfactsheets/strawwat.html>

EPA Fiber Rolls Fact Sheet:
http://cfpub.epa.gov/npdes/stormwater/menuofbmps/index.cfm?action=factsheet_results&view=specific&bmp=121

Treatment: HYDROMULCHING

Description: Hydromulch is a slurry of water, some form of wood fiber mulch, and often a tackifier (chemical compound used to increase the stickiness of the slurry) applied to burned areas deemed susceptible to erosion (i.e., low to moderate slopes and/or highly erosive soils, particularly those adjacent to surface water features, which have been partially or completely denuded of vegetation). When seed is included in the slurry for revegetation purposes the treatment is called hydroseeding (refer to seeding guidelines in this document when considering this type of treatment). Ground-based hydromulching is often applied from the road using a truck-mounted spray applicator.

Purpose: Hydromulching is used to prevent soil erosion and foster plant growth in high risk areas by immediately creating temporary soil cover, thereby reducing raindrop impact and binding together loose soil and ash to protect from overland flows and wind, while increasing soil water retention.

Methods and Guidelines:

- This treatment is primarily restricted to areas that are close to roads, bridges, homes or other structures because good access roads are necessary for the applicator.
- Generally, the contractor who applies the treatment will be responsible for properly dispensing the material. Application rates vary, but on average this treatment requires approximately 800 to 2,000 pounds of fiber per acre.
- Hydromulching may be less effective on long slopes because runoff water begins to concentrate and channelize as it flows down the hillside, carrying sediment and mulch with it.

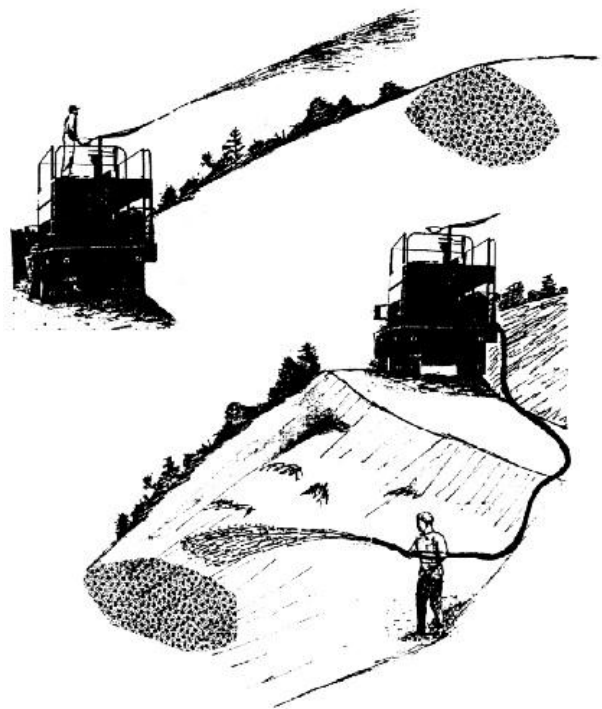

Additional Information:

USDA Forest Service Burned Area Emergency Response Treatment Catalog: (pages 21-24)

http://www.fs.fed.us/eng/pubs/pdf/BAERCAT/lo_res/06251801L.pdf

NRCS Hydroseeding and Hydromulching Fact Sheet:

<http://www.wy.nrcs.usda.gov/technical/ewpfactsheets/hydroseed.html>

LCRA Details for Erosion and Sediment Control after a Fire Event: (page 4)

http://www.lcra.org/library/media/public/docs/water/quality/water_WQ_ESCFireDetail.pdf

Treatment: SLASH SPREADING

Description: Slash spreading involves felling, lopping, chipping (mulching or shredding), and scattering low-value and fire-killed trees and brush across burned areas deemed susceptible to erosion (i.e., low to moderate slopes and/or highly erosive soils, particularly those adjacent to surface water features, which have been partially or completely denuded of vegetation). It is a common practice after timber harvesting operations, but can also be used on burned slopes where dead vegetation is present.

Purpose: Slash spreading is used to prevent erosion in high risk areas by creating longer term (two or more growing seasons) soil cover, interrupting rain impact, and absorbing moisture.

Methods and Guidelines:

- This treatment requires that burned areas have available slash material onsite or nearby.
- It can be used in a moderately burned area, where there is more material to spread, or below an intensely burned slope or area of highly erodible soils.
- In order to be effective, slash needs to be cut into small pieces so it makes good contact with the ground surface. Efficient slash creation generally involves mechanical equipment such as a chipper or grinder or a mulching attachment on a skid steer, tractor, or other heavy equipment. Chain saw-created slash is inefficient and ineffective in most cases due to the large amount of fine material needed to create adequate soil cover in contact with the ground.
- Operation of heavy equipment should not occur within 50 feet of perennial and intermittent streams.

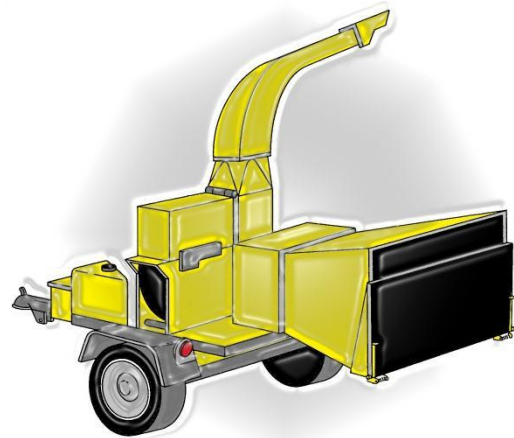

Additional Information:

USDA Forest Service Burned Area Emergency Response Treatment Catalog: (pages 31-33)
http://www.fs.fed.us/eng/pubs/pdf/BAERCAT/lo_res/06251801L.pdf

Texas Forestry Best Management Practices handbook:
http://texasforests.tamu.edu/sustainable/bmp_manual

EPA Mulching Fact Sheet:
http://cfpub.epa.gov/npdes/stormwater/menuofbmps/index.cfm?action=factsheet_results&view=specifi c&bmp=41

Treatment: STRAW MULCH SPREADING

Description: The application of straw over burned areas deemed susceptible to erosion (i.e., low to moderate slopes and/or highly erosive soils, particularly those adjacent to surface water features, which have been partially or completely denuded of vegetation). Straw mulch is often used in conjunction with seeding (refer to seeding guidelines in this document when considering this type of treatment).

Purpose: Straw mulch is used to prevent erosion in vulnerable areas by creating immediate but temporary ground cover, thereby reducing rain impact and absorbing rainfall. Straw mulch on burned areas also helps maintain a favorable moisture and temperature regime for seed germination and growth.

Methods and Guidelines:

- Can be applied by hand or using a blower pulled behind a light-duty truck (for roadside applications) in contour strips or broadcast to achieve a certain percent of ground cover.
- Generally, straw mulch is applied at a rate of 1 ton per acre, which corresponds to about 70% ground cover. The straw should be spread to a uniform depth of 2 to 3 inches. One typical square bale will cover about 800 square feet; an application rate of 2 tons per acre or approximately 54 bales per acre.
- Use only certified weed-free straw as problems can arise with straw containing exotic or invasive weeds. Exotic and invasive weeds displace native plants and decrease wildlife habitat, plant productivity, and diversity.
- Treatment failure is commonly attributed to wind blowing straw offsite or piling straw so deeply that vegetation is suppressed. When necessary, straw should be punched/crimped (forced into the soil), covered with netting (jute, wood excelsior, or plastic), or sprayed with a tackifier (a chemical compound used to increase the stickiness of the straw).
- Straw can be moved by runoff; however, it generally forms mini-debris dams of interlocking straw which still allows it to store some sediment and slow water velocity.



Additional Information:

USDA Forest Service Burned Area Emergency Response Treatment Catalog: (pages 25-30)
http://www.fs.fed.us/eng/pubs/pdf/BAERCAT/lo_res/06251801L.pdf

LCRA Details for Erosion and Sediment Control after a Fire Event: (page 3)
http://www.lcra.org/library/media/public/docs/water/quality/water_WQ_ESCFireDetail.pdf

NRCS Straw Mulching Fact Sheet:
<http://www.wy.nrcs.usda.gov/technical/ewpfactsheets/strawmul.html>

EPA Mulching Fact Sheet:
http://cfpub.epa.gov/npdes/stormwater/menuofbmps/index.cfm?action=factsheet_results&view=specific&bmp=41

Treatment: SEEDING

Description: In areas where natural germination and regrowth of vegetation on the forest floor is compromised or unlikely, given soil disturbing activities or in large severely-burned areas, some landowners may consider seeding to protect against erosion. Since scorched and lightly burned areas typically recover quickly from wildfire, reseeding for erosion control is usually limited to vulnerable areas within moderately to heavily burned landscapes.

Purpose: Seeding is used to control runoff and erosion on vulnerable areas (i.e., low to moderate slopes and/or highly erosive soils, particularly those adjacent to surface water features, which have been partially or completely denuded of vegetation) by artificially establishing vegetative cover from seed prior to natural revegetation of a site. It is also used to improve water quality and quantity by reducing sediment loads, sequestering pollutants in runoff and improving water infiltration to aquifers.

Methods and Guidelines:

- Use a combination of native grass and forb species only. Artificial seeding of non-local seed can change the dominance of the various species, which can be detrimental to the needs of native wildlife, and often does not produce better results than allowing natural vegetation recovery.
- Temporary cover seed should be applied between September 1 and December 1. Plants will germinate after the first rain and persist through the spring. The optimum planting window for a long-term restoration seed mix is February 15 through May 15, with plants germinating in late spring and continuing through summer.
- Minimize erosion by using seeding methods that will limit the amount of soil disturbance. These include seeding by hand (broadcasting with a hand-operated seeder), hydroseeding, or aerial seeding methods.
- Because seeding with native plants alone is ineffective for erosion protection during the first year, it can be used in combination with other erosion control treatments outlined in this guide, and may be used with a temporary cover seed mix. This also prevents seed from washing during rainfall events.



Additional Information:

USDA Forest Service Burned Area Emergency Response Treatment Catalog: (pages 63-67)
http://www.fs.fed.us/eng/pubs/pdf/BAERCAT/lo_res/06251801L.pdf

EPA Seeding Fact Sheet:
http://cfpub.epa.gov/npdes/stormwater/menuofbmps/index.cfm?action=factsheet_results&view=specifi c&bmp=42&minmeasure=4

Treatment: SILT FENCE

Description: Silt fence is a temporary barrier made of woven wire and fabric filter cloth (Geotextile) that is used to catch sediment-laden runoff from small burned over areas where erosion rates are expected to be high (i.e., low to moderate slopes and/or highly erosive soils, particularly those adjacent to surface water features, which have been partially or completely denuded of vegetation).

Purpose: Silt fence is primarily used to provide erosion control, catching material that has been eroded from a small sloping area. Silt fence works as a filter to trap soil and sediments, but allow water to slowly pass through. When multiple silt fences are used along a slope they function similar to contour felling or fiber roll treatments.

Methods and Guidelines:

- Silt fences should be installed on the contour of a slope perpendicular to the direction of surface runoff flow. Silt fences should not be installed across drainage ways, swales, gullies, ditches or other areas of concentrated water flow.
- As a general rule of thumb, the area that contributes runoff to be caught by the silt fence should not be greater than 1/2 acre for every 100 feet of fence.
- Dig a trench at least 4 to 6 inches deep on the upslope side and bury the bottom portion of the silt fence with soil to make sure no runoff can seep underneath.
- Keep the silt fence upright and tightly-stretched while installing. Install additional staking or straw bales behind the silt fence (on the downhill side) as necessary to prevent it from blowing-out.
- Inspect silt fences weekly and after each rain event (of 0.5 inches or more) to locate and repair any damage. Remove sediment when buildup reaches 6 inches. Silt fences should be removed when they have served their useful purpose, but not before the upslope area has been permanently stabilized.

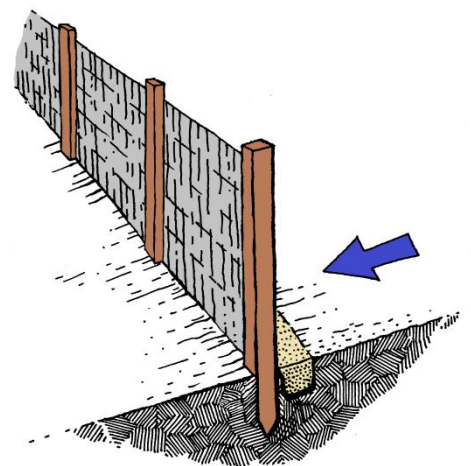

Additional Information:

USDA Forest Service Burned Area Emergency Response Treatment Catalog: (pages 55-58)
http://www.fs.fed.us/eng/pubs/pdf/BAERCAT/lo_res/06251801L.pdf

LCRA Details for Erosion and Sediment Control after a Fire Event: (pages 7-8)
http://www.lcra.org/library/media/public/docs/water/quality/water_WQ_ESCFireDetail.pdf

NRCS Silt Fence Fact Sheet:
<http://www.mt.nrcs.usda.gov/technical/eng/ewp/siltfence.html>

EPA Silt Fence Fact Sheet:
<http://cfpub.epa.gov/npdes/stormwater/menuofbmps/index.cfm?action=browse&Rbutton=detail&bmp=56&minmeasure=4>

